

QQC-020S机器人自动快换 (带传感器)

QQC-020S Robot automatic quick changer (with sensor)

- 载重20kg;
- 采用钢球锁紧方式;
- 具有防尘功能;
- 采用机械式自锁设计;
- 防止气源意外切断时两侧分离;
- 可选配PNP或NPN传感器。
- Payload capacity 20 kg;
- Steel ball lock system;
- With dustproof function;
- Adopt the mechanical self-locking design;
- Prevent separation from separating when when source of cut off;
- PNP or NPN sensor is available.

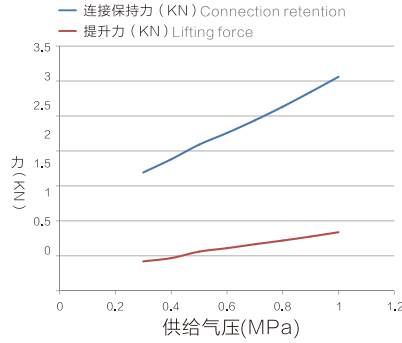
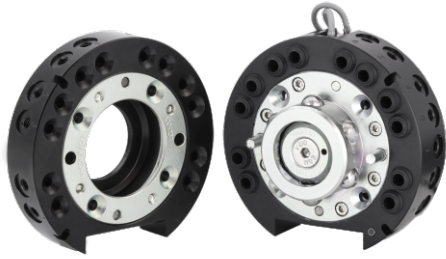

QQC-020S连接力、提升力曲线图
QQC-020S Continuous relay, lifting force curve

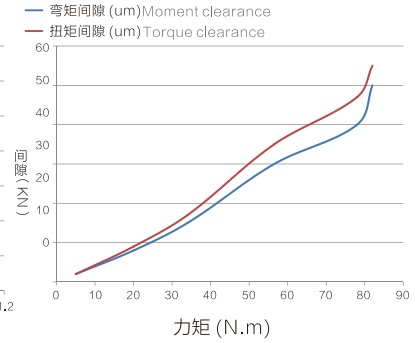

QQC-020S弯矩、扭矩变位曲线图
QQC-020S Bending moment and torque changer curve

规格参数 Specifications

本体部分 Mainbody	可搬运重量(额定负载)Payload capacity	20kg	
	位置重复精度 Positon repeatability	±0.02mm	
	静态允许力矩 Static allowable torque	弯矩方向 Bending direction(Mx.My)	5.5N.m
		扭矩方向 Torque direction(Mr)	78N.m
	锁紧力 (当气压 0.49Mpa时)Tight locking force (When the air pressure is 0.49Mpa)	2090N	
	材质 Material	本体 Main body	铝合金 Aluminum alloy
		锁紧机构部分 Locking mechanism	合金钢 Alloy steel
	外形尺寸(锁紧时Lock) Housing diameter(Lock when locked)	Φ90xH53.6mm	
	产品重量 Product weight	机器人侧 Robot side	0.48kg
		工具侧 Tool side	0.34kg
拆装结构 Disassembling institutions	钢球定位锁紧 Steel ball position lock		
拆装动作气压 Disassembling action pressure	0.39~0.7MPa(4~7kgf/cm ²)		
允许温度与湿度范围 Allowable temperature and humidity range	0~55℃, 0~95%(不结露No condensation)		
组件 Component (选配 Option)	通用 General	通气孔 Pneumatic port	M5 x12个
	通用 General	电信号点 Electrical signal	2A x19PIN/5A x12PIN

模块安装说明 MODULE INSTALLATION DESCRIPTION

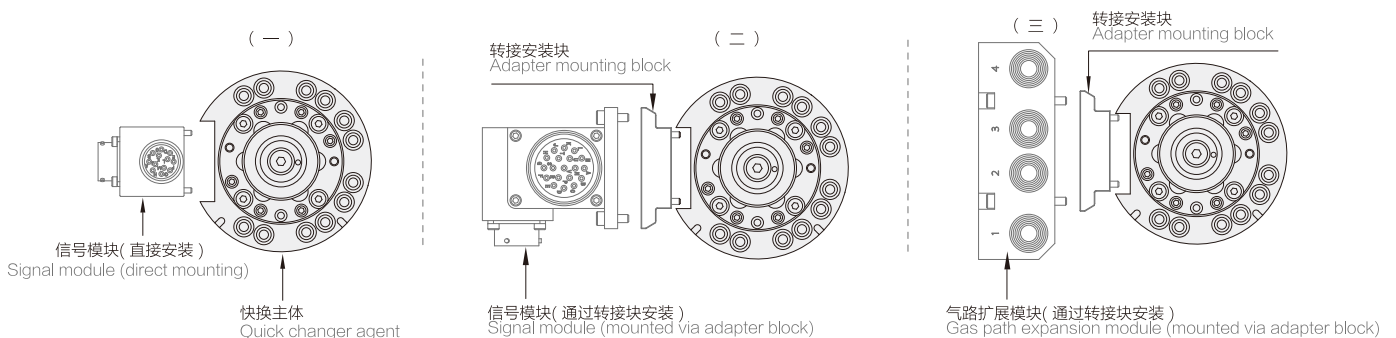

▶ 外形尺寸 OVERALL DIMENSIONS

机器人侧: OQC-020S-A
Robot side

订货编号: 7.03.01.0007
Order number

单价:
Price

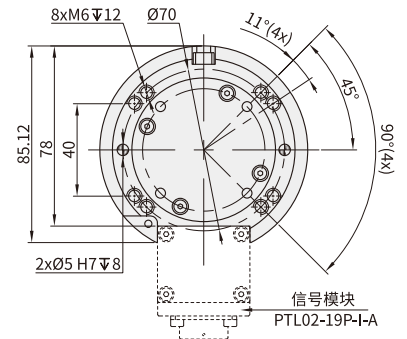
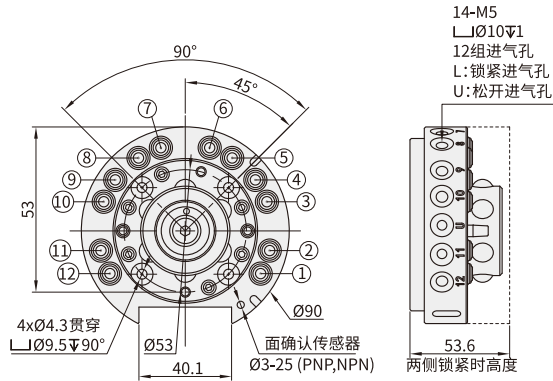
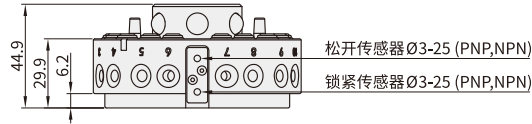

工具侧: OQC-020-B
Tool side

订货编号: 7.03.01.0008
Order number

单价:
Price

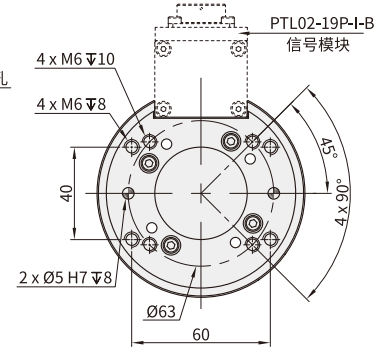
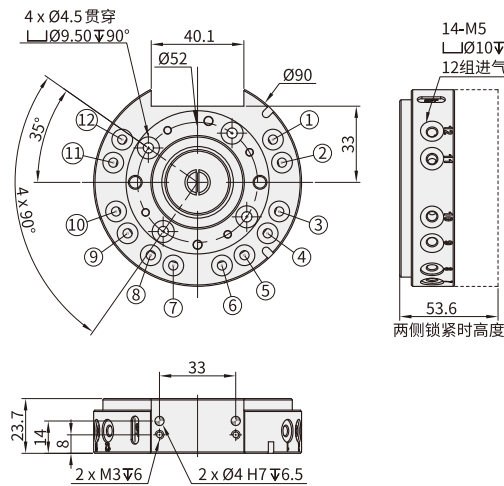

▶ 安装说明 INSTALLATION DESCRIPTION

机器人手臂 Robot arm

连接法兰 Connecting flange

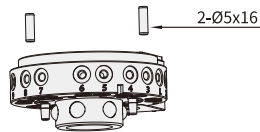

4-M4x35
安装板攻 M4 牙
Flange mounting plate
tapping M4 teeth

4-M4x35
安装板攻 M4 牙直接安装
Mounting plate tapping M4
teeth Directly installed

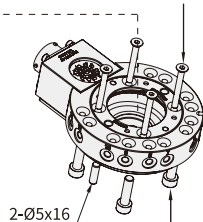

4-M6x25
连接夹具安装, 安装板 Ø6.5 过孔
Connecting fixture fixture, mounting
plate Ø6.5 through hole

电气连接器: PTL05-12P-I-A
Electrical connector PTL02-19P-I-A

电气连接器: PTL05-12P-I-B
Electrical connector PTL02-19P-I-B

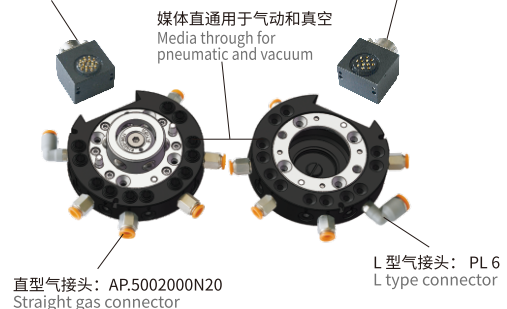

直型气接头: AP.5002000N20
Straight gas connector

L型气接头: PL 6
L type connector