

## OQC-076机器人自动快换 OQC-076 Robot automatic quick changer

- 载重80kg;
- 采用钢球锁紧方式;
- 具有防尘功能;
- 采用机械式自锁设计;
- 防止气源意外切断时两侧分离;
- 锁紧松开动作信号反馈(光电传感器);
- 面结合确认信号检测(光电传感器);
- Payload capacity 80 kg;
- Steel ball lock system;
- With dustproof function;
- Adopt the mechanical self-locking design;
- Prevent separation from separating when source of cut off;
- Lock and release action signal feedback(Photoelectric siwitch);
- Surface combined with cnfirmation signal detection (photoelectric switch);

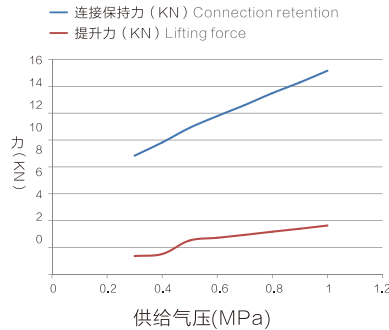

OQC-076连接力、提升力曲线图  
OQC-076 Continuous relay, lifting force curve

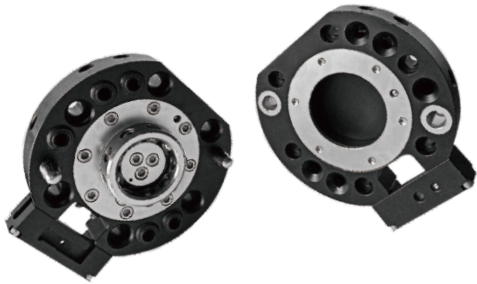
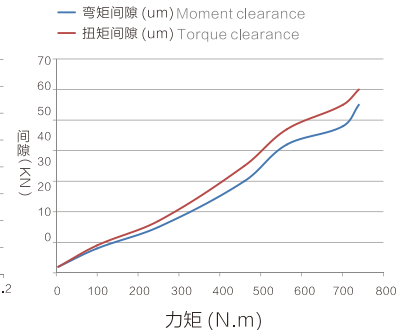

OQC-076弯矩、扭矩变位曲线图  
OQC-076Bending moment and torque changer curve

### 规格参数 Specifications

本体部分 Mainbody	可搬运重量(额定负载)Payload capacity	80kg	
	位置重复精度 Positon repeatability	± 0.02mm	
	静态允许力矩 Static allowable torque	弯矩方向 Bending direction( Mx.My)	564N.m
		扭矩方向 Torque direction( Mr)	701N.m
	锁紧力 (当气压 0.49Mpa时)Tight locking force (When the air pressure is 0.49Mpa)	10910N	
	材质 Material	本体 Main body	铝合金 Aluminum alloy
		锁紧机构部分 Locking mechanism	合金钢 Alloy steel
	外形尺寸(锁紧时Lock) Housing diameter(Lock when locked)	Φ 160mmxH67.5mm	
	产品重量 Product weight	机器人侧 Robot side	1.63kg
		工具侧 Tool side	0.91kg
	拆装结构 Disassembling institutions	钢球定位锁紧 Steel ball position lock	
	拆装动作气压 Disassembling action pressure	0.39~0.7MPa(4~7kgf/cm <sup>2</sup> )	
	允许温度与湿度范围 Allowable temperature and humidity range	0~55℃, 0~95%(不结露No condensation)	
	通用 General	通气孔 Pneumatic port	G1/4 x5个
控制部分 Control body	拆卸确认传感器 Remove confirmation sensor	抓取动作确认Grasp action confirmation	内置1个接近传感器 a proximity proximity sensor(直流3线式)
		松开动作确认Loosen action confirmation	内置1个接近传感器 a proximity proximity sensor(直流3线式)
	在位传感器 Reign sensor	确认工具在位 Confirm tool reign	内置1个接近传感器 a proximity proximity sensor(直流3线式)
组件 Component (选配 Option)	通用 General	电信号点 Electrical signal	2A x19PIN/2A x23PIN/20A x8PIN

# 机器人自动快换 ROBOT AUTOMATIC QUICK CHANGER

## 外形尺寸 OVERALL DIMENSIONS

机器人侧 Robot side

型号 Model number	传感器 Sensor	订货编号 Part number	单价 Price
OQC-076-A	无 Nil	7.03.01.0063	
OQC-076-AN	NPN	7.03.01.0112	
OQC-076-AP	PNP	7.03.01.0113	

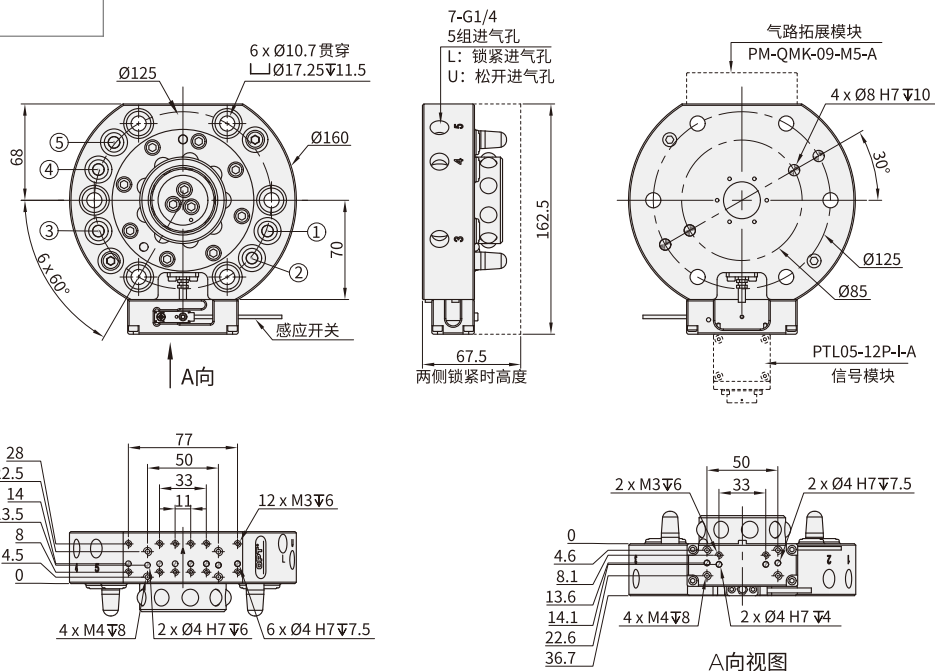

工具侧: OQC-076-B

Tool side

订货编号: 7.03.01.0019

Order number

单价:

Price

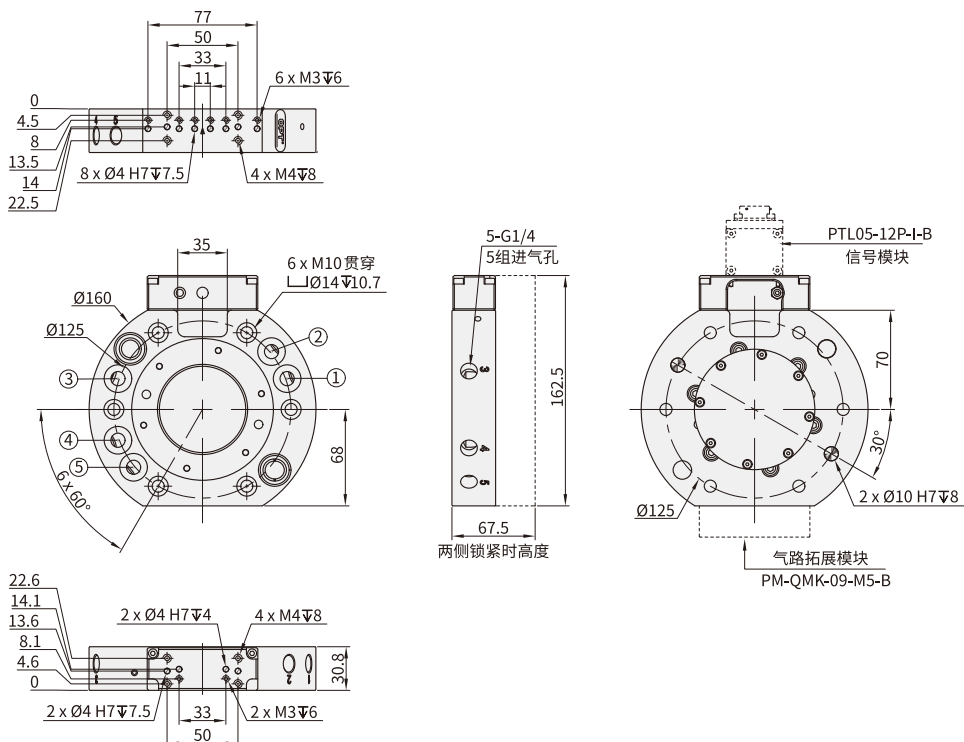
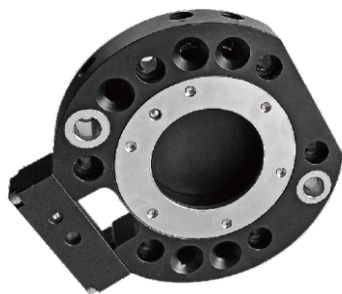

## ▶ 安装说明 INSTALLATION DESCRIPTION

