

OQC-040机器人自动快换 OQC-040 Robot automatic quick changer

- 载重40kg;
- 采用钢球锁紧方式;
- 具有防尘功能;
- 采用机械式自锁设计;
- 防止气源意外切断时两侧分离;
- Payload capacity 40 kg;
- Steel ball lock system;
- With dustproof function;
- Adopt the mechanical self-locking design;
- Prevent separation from separating when when source of cut off;

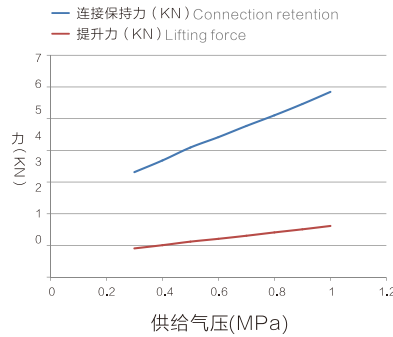

OQC-040连接力、提升力曲线图
OQC-040 Continuous relay, lifting force curve

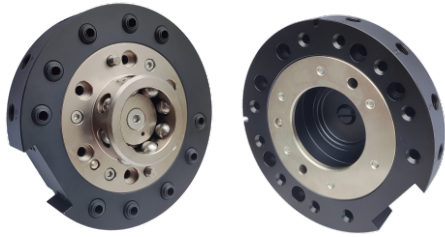
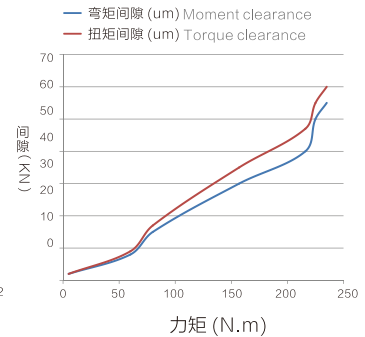

OQC-040弯矩、扭矩变位曲线图
OQC-040 Bending moment and torque changer curve

规格参数 Specifications

本体部分 Mainbody	可搬运重量(额定负载) Payload capacity	40kg	
	位置重复精度 Position repeatability	± 0.02mm	
	静态允许力矩 Static allowable torque	弯矩方向 Bending direction(Mx.My)	157N.m
		扭矩方向 Torque direction(Mr)	216N.m
	锁紧力(当气压 0.49Mpa时) Tight locking force (When the air pressure is 0.49Mpa)	4090N	
	材质 Material	本体 Main body	铝合金 Aluminum alloy
		锁紧机构部分 Locking mechanism	合金钢 Alloy steel
	外形尺寸(锁紧时Lock) Housing diameter(Lock when locked)	Φ 130mmxH60.2mm	
	产品重量 Product weight	机器人侧 Robot side	1.39kg
		工具侧 Tool side	0.84kg
拆装结构 Disassembling institutions	钢球定位锁紧 Steel ball position lock		
拆装动作气压 Disassembling action pressure	0.39~0.7MPa(4~7kgf/cm ²)		
允许温度与湿度范围 Allowable temperature and humidity range	0~55℃, 0~95%(不结露No condensation)		
通用 General	通气孔 Pneumatic port	M5 x10个	
组件 Component (选配 Option)	通用 General	电信号点 Electrical signal	2A x19PIN/5A x12PIN

模块安装说明 MODULE INSTALLATION DESCRIPTION

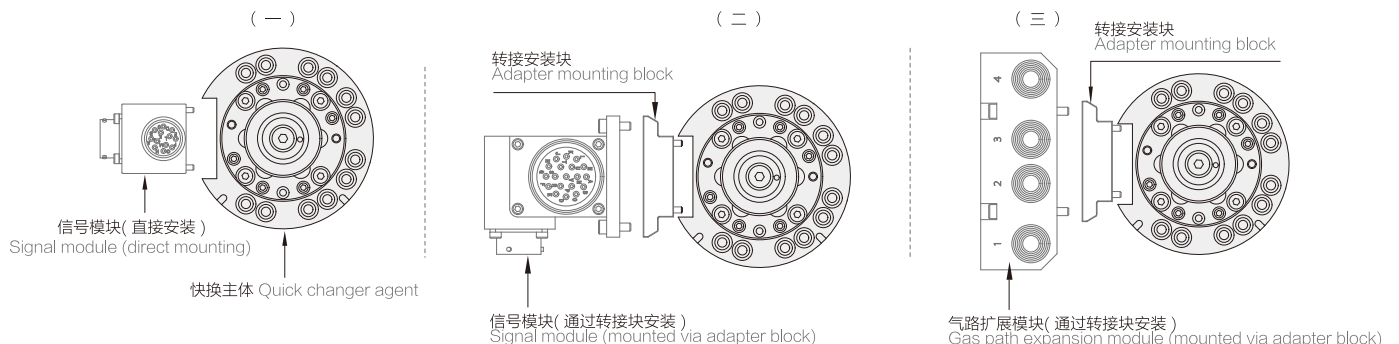

机器人自动快换 ROBOT AUTOMATIC QUICK CHANGER

外形尺寸 OVERALL DIMENSIONS

机器人侧: OQC-040-A

Robot side

订货编号: 7.03.01.0015

Order number

单价:

Price

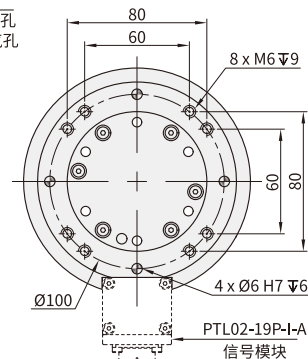
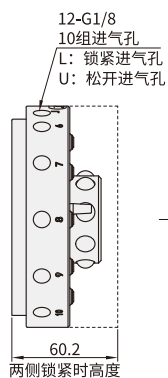
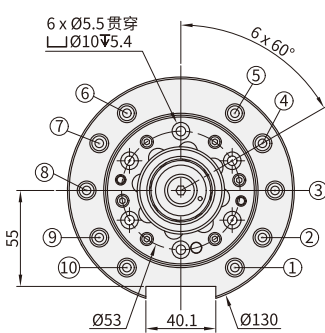
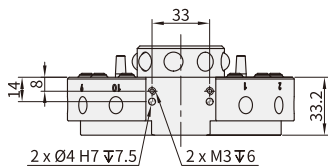

工具侧: OQC-040-B

Tool side

订货编号: 7.03.01.0016

Order number

单价:

Price

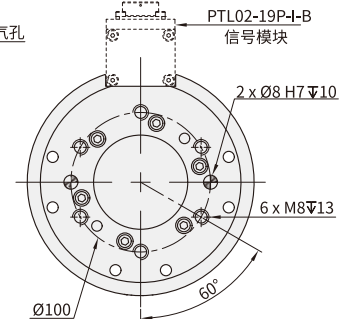
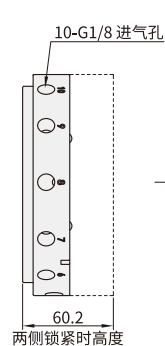
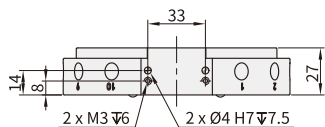
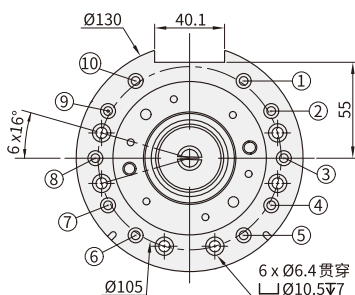
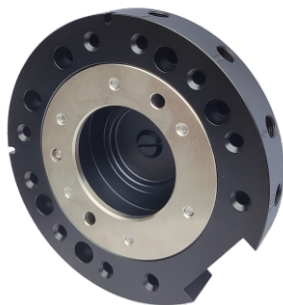

安装说明 INSTALLATION DESCRIPTION

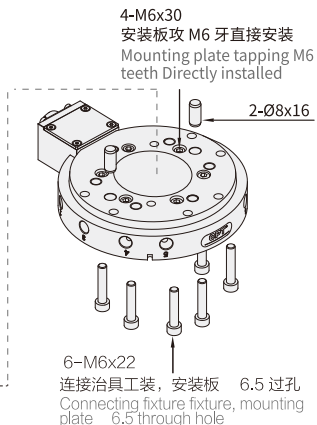
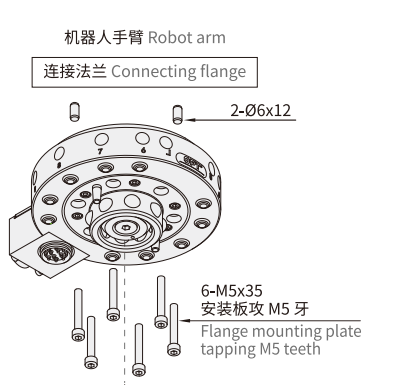

电气连接器: PTL05-12P-I-A
Electrical connector PTL02-19P-I-A

电气连接器: PTL05-12P-I-B
Electrical connector PTL02-19P-I-B

